

Teachers and Youth Leaders: Copy the next page to the back of this front page in order to make the correct front and back paper airplane copies for students, OR order CAP paper airplanes by contacting ae@capnhq.gov.

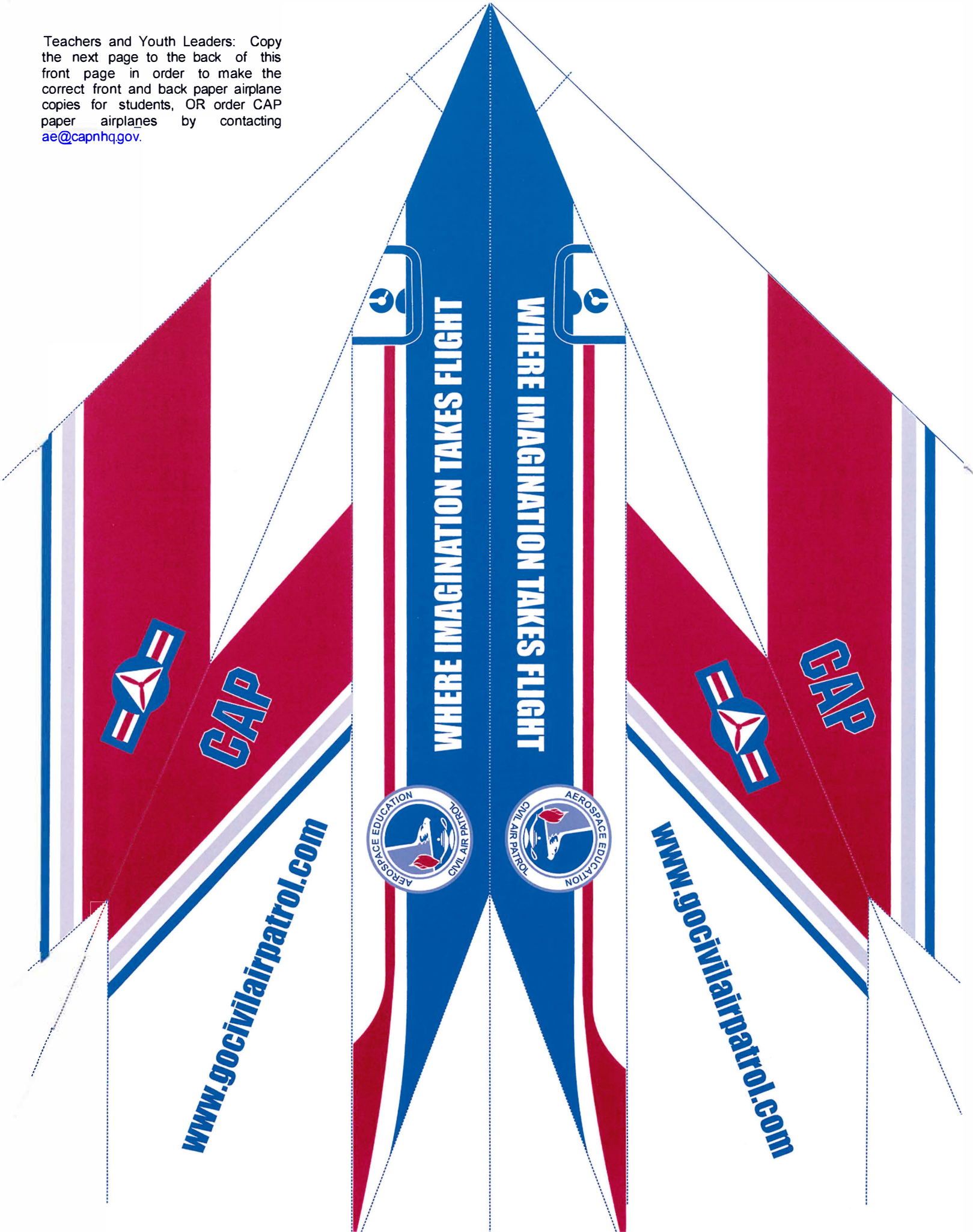

WHERE IMAGINATION TAKES FLIGHT

WHERE IMAGINATION TAKES FLIGHT

www.gocivilairpatrol.com

www.gocivilairpatrol.com



CAP



CAP

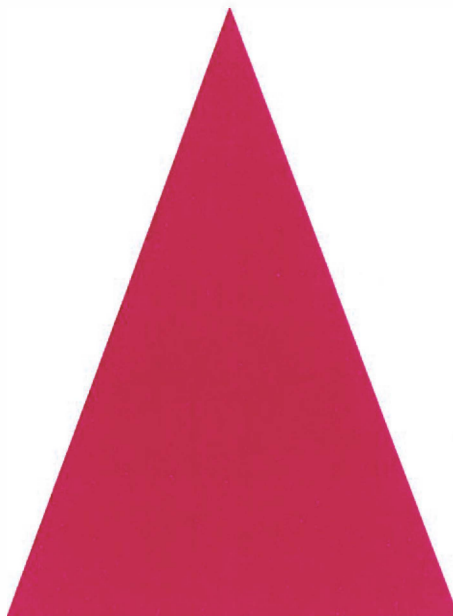

LESSON PLAN FOR CAP PAPER AIRPLANE

Objective: To present the four forces of flight and experiment with airplane control surfaces through the use of a paper airplane.

National Science Content Standards:
(Source: National Research Council)
Science as Inquiry

- Abilities necessary to do scientific inquiry
- Understanding about scientific inquiry

Physical Science

- Motions and forces

Science and Technology

- Abilities of technological design

Unifying Concepts and Processes

- Evidence, models and explanations
- Form and function

Background Information:

There are four forces acting on an airplane in flight: lift, gravity, thrust, and drag. A force is a push or a pull, and the four forces of flight affect the direction and motion of the airplane.

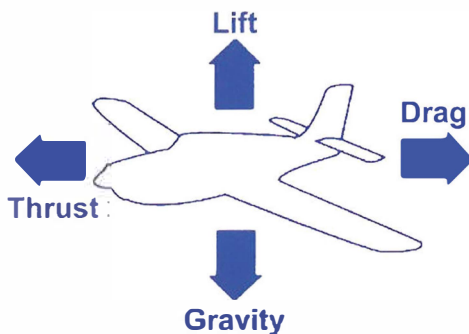

1. **Lift** is the force that holds an airplane in the air. The wings create most of the lift due to the wing's special shape and how air flows over the wing. The slower air moving under the wing creates a higher pressure which helps push the wing up.
2. **Gravity** is the force that pulls everything toward the ground. This "pulling down force" is what causes something to have weight that can be measured on a scale.
3. **Thrust** is a force that moves an object in the direction of the motion. It can be created with a propeller, jet engine, or rocket. With a propeller or jet engine, air is pulled in and then pushed out in an opposite direction. Throwing an object creates thrust, as well.

4. **Drag** is the force that acts opposite to the direction of motion. Drag, caused by air resistance, slows an airplane.

The way the four forces act on the airplane makes the plane do different things. Each force has an opposite force that works against it. Lift works opposite of gravity. Thrust works opposite of drag. When the forces are balanced, a plane flies in a level direction. The plane goes upward if lift is greater than weight. The plane will go downward if weight is greater than lift. The plane will accelerate forward when thrust is greater than drag. The plane will slow down when drag is greater than thrust.

The airplane has many movable surfaces that work to control the direction of movement of the airplane.

1. The flaps, on the inside of each wing toward the fuselage (body) of the plane, work to slow the speed of the plane, adding the force of "drag."
2. The ailerons, on the outside end of each wing, work to make the airplane "roll" when one aileron is up and the other is down.
3. The rudder, on the vertical stabilizer, turns the plane left or right.
4. The elevators, located on the rear of the airplane, move, or pitch, the plane upward or downward.

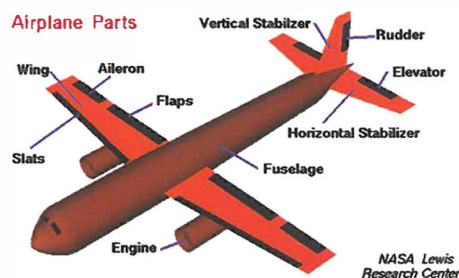

On the paper glider you will be making, some of the parts (which are labeled on the next page) include:

1. The vertical stabilizer at the rear of the plane stabilizes and controls the plane's flight.
2. The two winglets located on the tip of each wing help increase lift and reduce drag.
3. The two "elevons" at the rear of the plane are a combination of the ailerons and elevators.

- a. The elevons act as elevators when turned in the same direction: when both elevons are turned up, the plane moves upward (ascends); when both elevons are turned down, the plane moves downward (descends).
- b. The elevons act as ailerons when one elevon is turned up and the other down, which will make the airplane roll to the left or the right when thrown.

Procedures:

1. Fold the paper plane following the directions on the next page.
2. Experiment with angles of throws, angles of elevons, and amount of thrust to determine how to control the flight.
3. Have contests to determine highest flights, longest flights aloft, best control of direction, and best target mark.

Assessment: Have students identify the forces of flight and the surfaces that cause the plane to change direction by answering these questions.

1. Air flowing over and under the wings creates the force of _____.
2. _____ is the force that pulls the airplane down and is the opposite of lift.
3. The engines provide the force of _____.
4. _____ is the force working to slow the plane's motion.
5. The movable part on the horizontal stabilizer that moves the plane up and down is the _____.
6. A movable part that is "part aileron and part elevator" and allows the plane to roll or move up or down is called the _____.

Answers:

Additional Resources:

See interactive airplane parts and comparison to the Wright Brothers plane and the four forces of flight:

<https://wright.nasa.gov/airplane/forces.html>

https://www.grc.nasa.gov/WWW/K_12/airplane/forces.html

AIRPLANE FOLDING INSTRUCTIONS

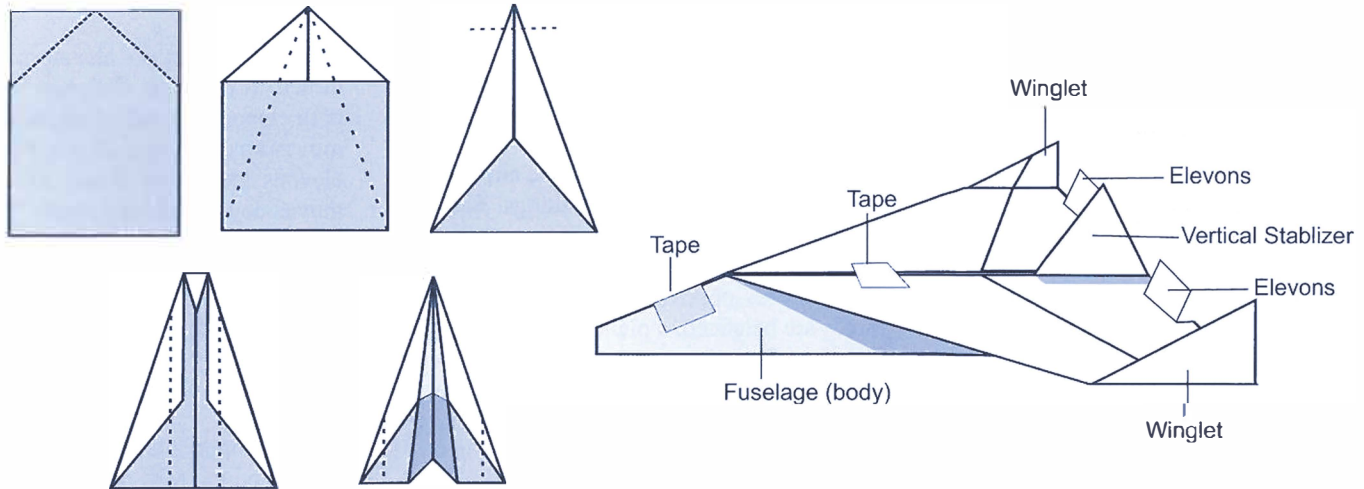

THE PLANE

- Flip the paper over so that the printed fold lines are facing down.
- Fold the top corners inward along the outside fold lines and crease down. Repeat for the next set of folds.
- Fold the nose back, as shown.
- Fold along the center line so the lines and graphics are on the outside.
- Fold down each wing and fold up the corner flaps.
- Tape together nose, wing and fuselage for optimum performance.
- Throw smoothly.

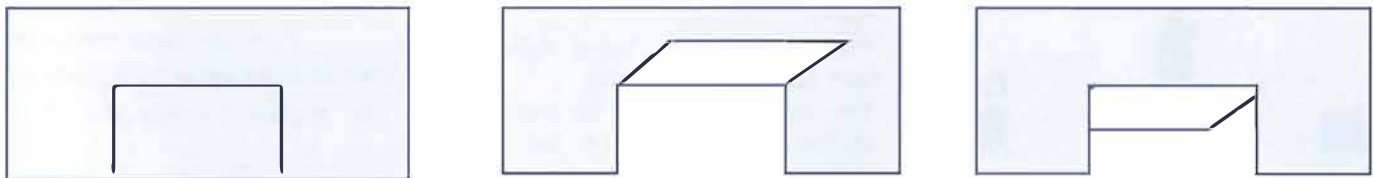

THE ADJUSTABLE ELEVONS

- Cut on sides, as shown.
- Fold up to make the plane rise...fold down to make the plane drop.
- Fold one up and one down to make the plane roll.

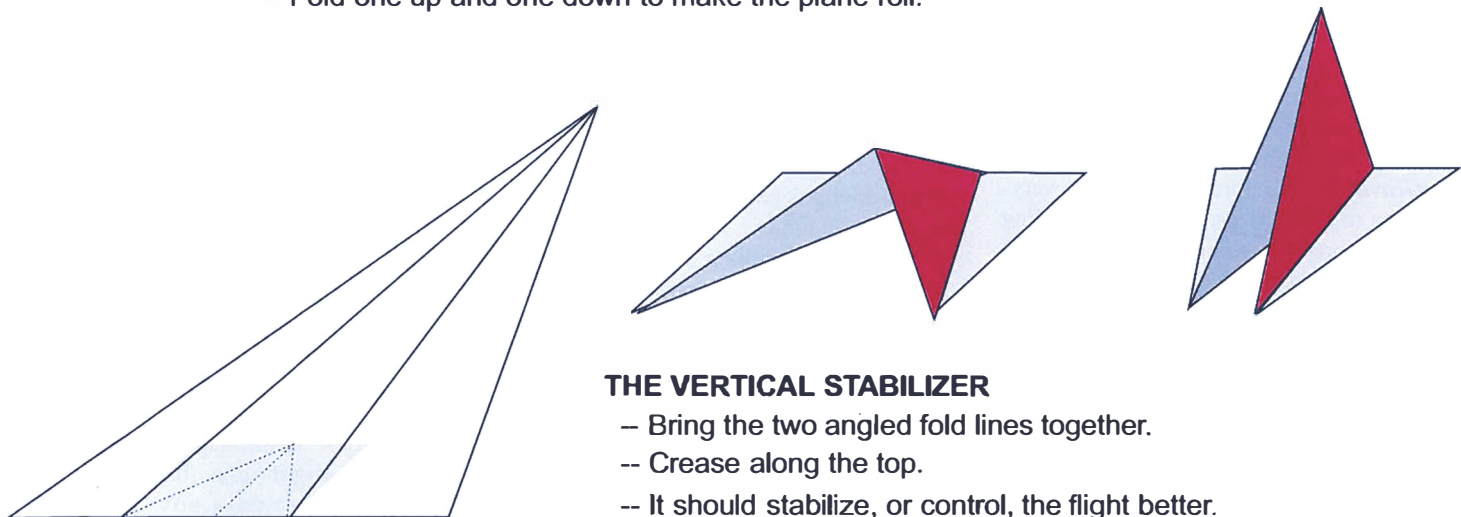

THE VERTICAL STABILIZER

- Bring the two angled fold lines together.
- Crease along the top.
- It should stabilize, or control, the flight better.